

Beep: 3D Indoor Positioning Using Audible Sound

Atri Mandal, Cristina V. Lopes, Tony Givargis, Amir Haghghat, Raja Jurdak and Pierre Baldi
School of Information and Computer Science
University of California
Irvine, CA 92697
{mandala, lopes, givargis, ahaghigh, rjurdak, pfbaldi} @ ics.uci.edu

Abstract—Rapid growth in the number of wireless enabled devices has led to an increased interest in location-aware applications. The backbone of such applications is provided by a location system. In this paper we present Beep, an indoor location system that senses audible sound. The use of audible sound makes our system cheap and easily deployable to most existing roaming devices. Unlike positioning systems using ultrasound and infrared signals, Beep does not require the user to carry any kind of specialized hardware. Our system is based on standard 3D multilateration algorithms. However, the requirement of being able to locate existing devices, whose sound cards were not designed for high-precision signaling, introduces additional challenges to the location problem. This paper describes how those problems were solved and presents experimental results. Beep works with an accuracy of about 2 feet in more than 97% cases. The paper also describes a sensor deployment strategy that requires low sensor density and consequently low installation costs.

Keywords- *pervasive computing; location-based services; indoor positioning; audible sound; 3D multilateration; sensor density*

I. INTRODUCTION

One of the most popular research areas in ubiquitous or pervasive computing is the development of location-aware systems. These are systems in which computing devices provide the users with specific information depending on their location. The key component of a location-aware system is a location-sensing system.

In this paper our goal is to develop a cheap, easily deployable and universally compatible location system for indoor use. One of the most widely used location systems in the world is GPS, a satellite-based navigation system. However, GPS is not very useful as an indoor location system, because it requires that the receivers have direct line-of-sight to satellites. Some researchers have been successful, to a limited extent, in developing GPS based indoor location systems by using high-sensitivity receivers [12]. Others have used a combination of radio frequencies and ultrasound [3] or infrared signal [2] for indoor positioning. All these location systems have their own strengths and are very useful in their respective application domains (for a survey see [1]). However these systems are not suitable for indoor positioning in public places for ordinary users. Most of these systems need the use of

specialized hardware which is not easily available. Also, some of these systems are prohibitively expensive for wide deployment.

In our attempt to build a location system that is both cheap and universally applicable we chose to sense audible sound, because it is available in virtually all roaming devices. In our positioning system we use a PDA (or equivalently, any other roaming device with wireless capability) as a cheap locating device. The use of audible sound eliminates the need for additional infrastructure at the user end. Beep has a sufficiently high level of accuracy for most practical applications, as demonstrated by our experimental results. We envision applications of Beep in places like large departmental stores, shopping plazas, amusement parks, museums, public libraries, office buildings etc.

The remainder of this paper is organized as follows. Section II provides background information and reviews related work. Section III describes the architecture of our indoor positioning system in detail along with the implementation challenges. Section IV summarizes the results obtained in an indoor environment. Section V concludes the paper with a brief outline of future work.

II. RELATED WORK

Previous work related to the development of indoor location systems can be broadly classified on the basis of the media used to sense location. There are mainly three categories namely, infrared, (ultra)sound and radio. This section discusses each of these in brief.

The earliest proposed indoor location systems used infrared. In Active Badge [2] users wear badges that emit diffuse infrared signals. Pre-installed sensors detect the infrared signals and report them to a central server. However, infrared waves have several undesirable features for location systems, including interference from florescent light and sunlight.

Other systems, such as Active Bat [3] and Cricket [4], use ultrasound signals. Active Bat's architecture is similar to Active Badge in that it requires mobile users to wear ultrasound tags. Ceiling-mounted ultrasound receivers capture the tag's signal and report it to the central server. Active Bat uses an ultrasound time-of-flight lateration technique, in which the user sends both

an ultrasound and radio signal, and the system computes the difference in arrival times between the two signals to determine the user's position. Cricket enhances Active Bat by using the radio signal arrival time to narrow the time window in which arriving signals are considered. Dolphin [5] is another ultrasound positioning system with a distributed flavor. In Dolphin, the location of only a few nodes is known, and the remaining nodes can infer their own location based on the location of reference nodes.

Because of their reliance on technologies such as infrared and ultrasound, these location systems require the user to acquire additional hardware such as badges or tags. Therefore some location systems proposed the use of hardware that is already present in roaming devices. RADAR [6] uses the signal to noise ratio and signal strength of a mobile user's IEEE 802.11 transmissions to locate the user in a 2D environment. However such systems have significantly lower resolution.

Audible sound has been recently considered for ubiquitous computing and communications applications. Lopes and Aguiar [7] have explored the use of musical sounds and other familiar sounds for low bit rate communications using hardware that is readily available in desktop computers, palm devices, televisions and other electronic devices. The work in [8] also proposes the use of audible sound for low bit rate communications, as well as for indoor location systems. In this location architecture, one of several listeners detects the acoustic signal and reports the signal characteristics to a central server. The aim is to identify the room in which the user is located. The work in [9] considers an outdoor location system based on a network of acoustic sensors to provide high location accuracy at considerable monetary cost for military and scientific applications. The system in [9] assumes a fully distributed self-organizing architecture where the sensors discover the topology and integrate into the network. It employs complex algorithms for sensor synchronization, as well as beam forming techniques to determine the direction from which the signal arrives at the microphone.

III. SYSTEM OVERVIEW

Beep is a 3D location system which uses audible sound for positioning. We chose audible sound because it is widely supported by existing devices (cell phones, PDAs, desktops etc.), making it the basis for a cheap and pervasive location system. Audible sound eliminates the need for additional infrastructure at the user end. Beep provides positioning on demand, i.e. position is computed only when the user requests it. This design decision was driven by social and technical reasons. We don't want people to feel they are being tracked, so the locating request is controlled by the user. At the same time, the on-demand location saves power by avoiding constant communication between the user's device and the sensors.

Beep uses an architecture similar to [8] to sense the user's location but has much higher granularity. While the location system in [8] aims to identify the room in which the user is located, our positioning system can locate the user's position within the room. It provides an accuracy of positioning comparable to the systems in Active Badge, Active Bat and Cricket, but using only a PDA as a locating device.

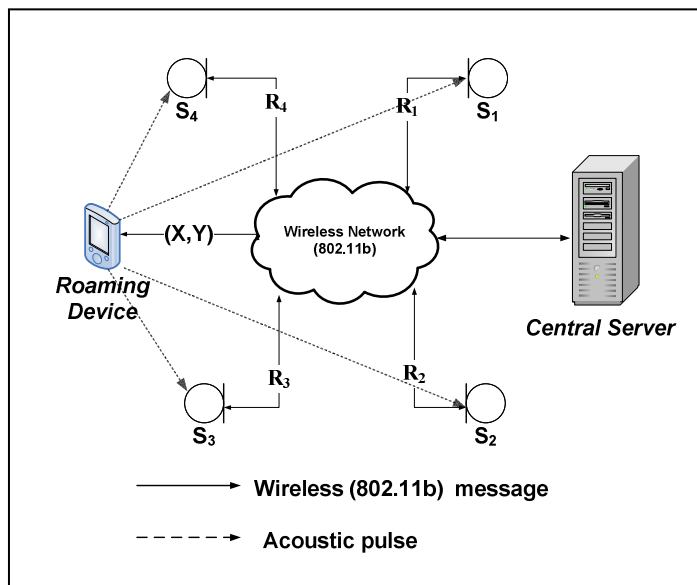

Figure 1. Overview of Beep

Figure 1 shows the architecture of Beep. The system consists of a set of acoustic sensors (S_i) that are connected to a central server through a wireless network. Each of these sensors has a processing unit, a wireless network interface card and a microphone for detecting acoustic signals. The user's roaming device is assumed to have wireless communication capability. We use the device's IP address to identify it on the network.

The protocol between the user's device and the rest of the system is as follows. When a user requests positioning, the user's roaming device synchronizes with the sensors through the wireless network, and transmits a pre-defined acoustic signal. The sensors detect this signal, using specialized digital filters, and make an estimate of the time-of-flight. The estimated time is translated into distance by multiplying by the speed of sound. The distances are then reported to the central server. The central server, knowing the precise location (coordinates) of each of the sensors, performs 3D multilateration to determine the coordinates of the user and reports the results to the roaming device.

While most of the methods and algorithms in Beep are similar to those in several existing location systems, its 3D multilateration algorithm is the most interesting part, as it differs considerably from existing ones. The reason for that comes from our goal of using roaming devices whose less-than-perfect hardware is fairly out of our control. Details are discussed in Section III.B.

A. Synchronization and Signal Detection

Beep uses a time-of-flight-based triangulation technique. To calculate time-of-flight the sensors have to know the exact time when the roaming device transmits the acoustic signal, and as such, they need to synchronize with the roaming device. The synchronization is done by exchanging messages through the wireless network, which acts as a fast communication channel between the users' roaming device and the sensors.

The signal detection makes use of a second order recursive IIR filter known as Goertzel filter which is efficient in detecting single frequencies in the presence of noise [10].

B. Triangulation in the Presence of Unknown Delays

In this section we present a general method of triangulation applicable to almost all roaming devices. Standard positioning algorithms use a 3D multilateration technique based solely on the time-of-flight reported by the sensors. However, extra precaution has to be taken when calculating time-of-flight for signals generated with a PDA or similar roaming devices. We observed that these devices introduce a significant delay caused by the soundcard. Therefore, the perceived time-of-flight is greater than the real time-of-flight, specifically it includes the delay. We also observed that the precise value of the delay depends on the device and, for that reason, cannot be factored out easily. The delay has significant impact on the accuracy of triangulation. Our triangulation technique, explained below, provides a device-independent method for estimating the accurate position in the presence of such unknown delays.

First let us assume ideal conditions where all n sensors report the correct distances r_i from the roaming device. Under such conditions, the following spherical equations hold, and have a unique solution $[x, y, z]$:

$$(x - X_i)^2 + (y - Y_i)^2 + (z - Z_i)^2 = r_i^2 \quad i = 1, 2, \dots, n \quad (1)$$

where $[X_i, Y_i, Z_i]$ is the position of the i^{th} sensor.

The value of $[x, y, z]$ can be solved using only 3 equations, provided we assume that all the sensors are in a single plane and the roaming device is somewhere below the plane of the sensors [11].

However, due to the presence of the unknown hardware delay the sensors will report larger distances than the real ones. We address this problem in the following way. Let us assume that, for a particular positioning request, the i^{th} sensor reports a distance R_i . We further assume, for simplicity, that $Z_i = 0$ i.e. all the sensors are in a single plane. The equations for the n sensors, then, take the general form:

$$(x - X_i)^2 + (y - Y_i)^2 + z^2 = (R_i - d)^2 \quad i = 1, 2, \dots, n \quad (2)$$

where d is the value of the unknown delay.

The family of equations in (2) has four variables and requires four equations for a deterministic solution. The solution can be obtained both analytically and iteratively. The analytical method is computationally fast but, due to errors in measured distances R_i , the equations in (2) will not yield an analytical solution in most of the cases. So we adopt an iterative approach which repeatedly shrinks the radii of the measured spheres by a small amount until the area of intersection reaches a small threshold value. We start with four spheres of radii R_i , $i = 1, 2, 3, 4$. At each iteration we shrink the radius of each of the spheres by a small amount, δ . Thus after k iterations we will have four spheres of radii $R_i - k\delta$, $i = 1, 2, 3, 4$. The terminating condition is that one of the points of intersection of the first three spheres gets sufficiently close to the surface of the fourth sphere, the closeness being determined by the given threshold.

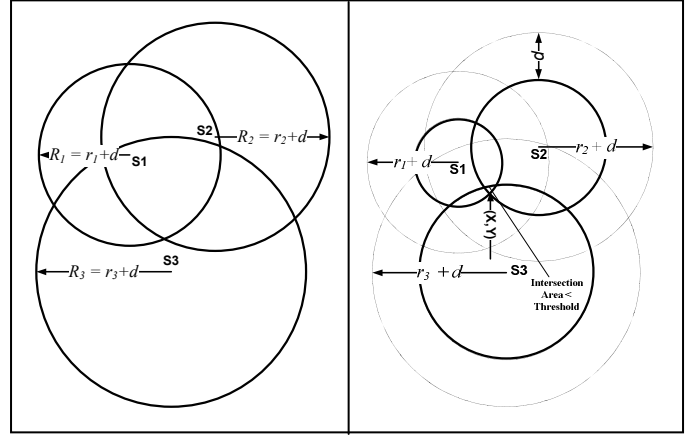

Figure 2. Circles before shrinking (left) and after shrinking (right)

Our solution is illustrated in Figure 2 using a 2D analogy – in 2D the spheres in (2) are replaced with circles. Figure 2a shows three circles obtained from the distances reported by the sensors. Figure 2b shows the circles after they have been shrunk by our algorithm. Our algorithm terminates in at most k steps where $k = \text{floor}(d/\delta)$.

C. Positioning Request Arbitration

Since the generation of positioning requests in the system is asynchronous, there is a possibility that two or more users request positioning at the same time or within a short time interval. This is a collision. In absence of a collision resolution strategy, the system will be unable to locate the devices properly. The probability of collisions increases with the number of users in the system.

We avoid this situation by making the central server maintain a queue to serialize incoming positioning requests. The requests are serviced in the same order as they appear in the queue. Even if two successive requests arrive within the collision interval the server will block the second requester till the first request has been serviced completely.

D. Sensor Deployment, Density and Coverage Area

We define sensor density as the number of sensors that have to be deployed in unit area within the system. In this section we describe how to optimize the sensor density and at the same time keep the results within desired limits of accuracy.

First we define the range R of an acoustic sensor, since it will be used in our calculations. Every sensor can detect signals correctly up to a certain distance from the source; if the sound source is at a greater distance, the received signal-to-noise ratio is too low for reliable detection. We call this distance the range of the sensor. Since we will be using sensors of the same kind in our system, we assume that the value of R is the same for all the sensors in the system. Since our algorithm needs at least four sensors for proper positioning we would have to place sensors such that every point within the physical area is within the range of at least four of them. Let the distance of the user from a particular sensor at any given point be r .

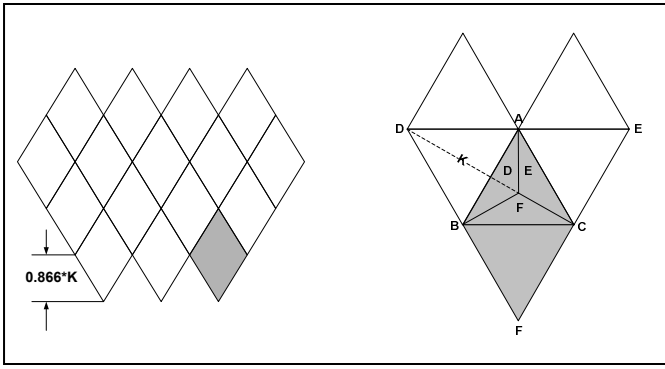

Figure 3. Sensor Coverage with Diamond Lattice Structure

If the sensors are all placed on the ceiling, the minimum length of projection P_r of the distance r on the plane of the sensors has the value $\sqrt{r^2 - H^2}$ where H is the height of the room. If $r=R$ the value of P_r is $\sqrt{R^2 - H^2}$ which we define as the constant K . We will be deriving equations for sensor density and separation in terms of this constant. We looked at two different methods of sensor coverage, namely:

Square lattice. A simple way of placing sensors is to arrange them in a single plane, at the vertices of a square having an edge of length $\frac{K}{\sqrt{2}}$. This will mean that every point within the square will have a maximum distance of K from the sensors at the vertices of the square. This configuration requires 4 sensors for every square cell having $\frac{K^2}{2}$ square units of area. However, when the number of cells, N , is large (i.e. in the asymptotic case) the sensor to cell ratio is 1:1. Therefore for large N we need only one sensor per square cell or $\frac{2}{K^2}$ per unit area. The main advantage of the square configuration is ease of deployment.

Diamond lattice. A more efficient way is to place the sensors at the vertices of a diamond (rhombus) having edge of length $K\frac{\sqrt{3}}{2}$ as shown in Figure 3. Each such diamond is composed of two equilateral triangles. Let us focus on $\triangle ABC$ in Figure 3 which is one half of the diamond ABFC. It is easy to see that any point within this triangle is within a distance of at most K from the nearest four vertices. Three of these vertices are A, B and C - the vertices of the triangle. The fourth vertex is D, E or F depending on the position of the point within the triangle. Similar argument holds for $\triangle BCF$.

This configuration requires 4 sensors for each cell of $\frac{3\sqrt{3}}{8}K^2$ square units. The sensor to cell ratio, for the asymptotic case is, again 1:1 i.e. $\frac{8\sqrt{3}}{9K^2}$ sensors per unit area. This value is less than the square case, so this method is more cost efficient when covering large areas. For example, to cover a warehouse of area 10000 sq. ft and height 10 ft with sensors having range 25 ft this method will need about 30 sensors while the former

method will need as many as 38. However for small areas the effective sensor density will be higher than the former case.

In real situations it may not be possible to tile the physical area exactly with one of the above arrangements. In such situations we will test the system at various points with an approximately similar arrangement. We will use our results to determine the correct positioning of sensors and rearrange the sensors accordingly and add or remove sensors if needed. So the actual sensor density will be slightly different from the theoretical value.

E. Signal Design

Finally we examine the acoustic signal used for location sensing. There are two parameters in the design of the signal, namely:

- i) Content of the signal – Since the timely detection of the transmitted acoustic signal is important we chose a simple signal consisting of a single frequency (4.01 KHz). This simplifies signal detection.
- ii) Duration of the signal – The duration of signal is short enough not to sound annoying and long enough to be reliably detected in the presence of noise. We chose a signal duration of 100 ms which makes the signal shorter than a DTMF tone.

In a real setting we might use a slightly different design to make the sound more pleasant to the human ear.

IV. TESTBED AND RESULTS

The testbed consists of a HP iPAQ (HP 5550) used as the roaming device, 6 Labtec Verse 333 PC microphones connected to desktops serving as acoustic sensors, and a Pentium PC acting as the central server. The iPAQ and the 6 sensors connect to the central server through 802.11b WLAN. The experiments were carried out in a room measuring 32 ft x 18 ft x 8ft. The microphones were placed on the ceiling, in a pattern resembling a section of the square lattice discussed in III.D.

Figures 4 -7 illustrate the results of our experiments. All measurements are in feet. Figure 4 shows the results of our experiments with 132 test points which trace out a path inside the room. The path reported by Beep is shown alongside the actual path taken. The placement of the acoustic sensors is also shown in the figure. The circled points correspond to the cases where the estimated position had an error of more than 2 ft (error being measured along X-Y plane). No points in Figure 4 reported more than 3 ft error. This experiment was conducted to test the technical feasibility of the system for users in a shopping mall or similar place. Figure 5 shows results when the object is moved vertically, i.e. along Z-axis, keeping X and Y constant. It can be seen that the accuracy of measurement, along the Z-axis is less than along the X and Y axes. We also performed experiments to determine the precision of the system i.e. consistency in the measurements. The results of our experiments are shown in Figures 6 and 7 and are derived from 100 measurements at each of 5 test points within the room. Figure 6 shows the results when only the X and Y coordinates of the measured location are taken into consideration. The dotted crosswires in the figure help in locating the actual test

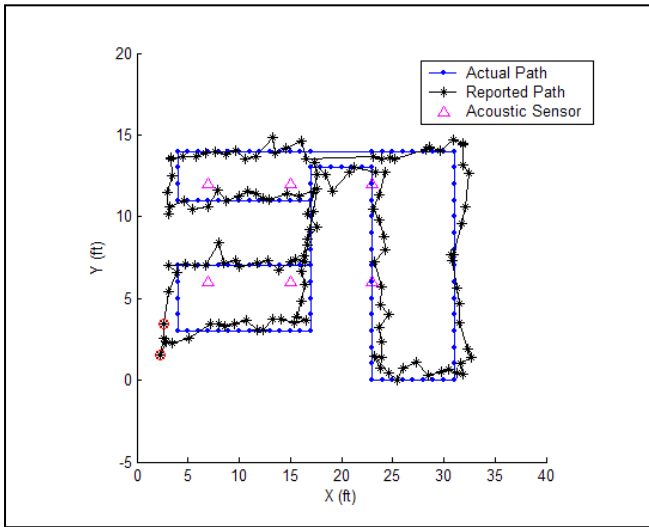

Figure 4. Reported vs. Actual Positions (along X-Y plane)

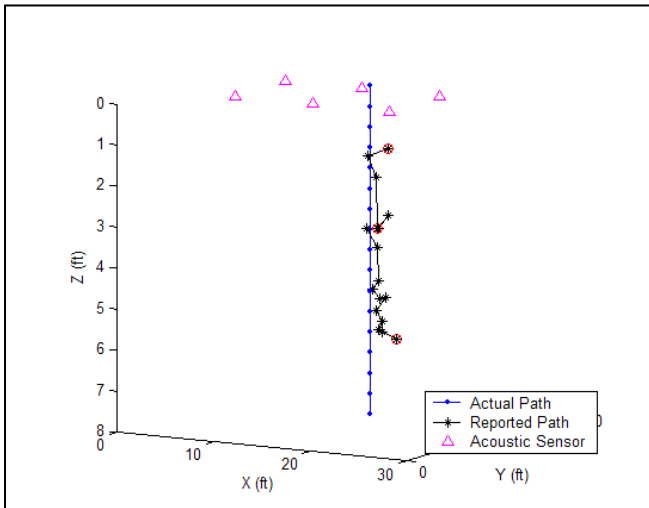

Figure 5. Reported vs. Actual Positions (along Z-axis)

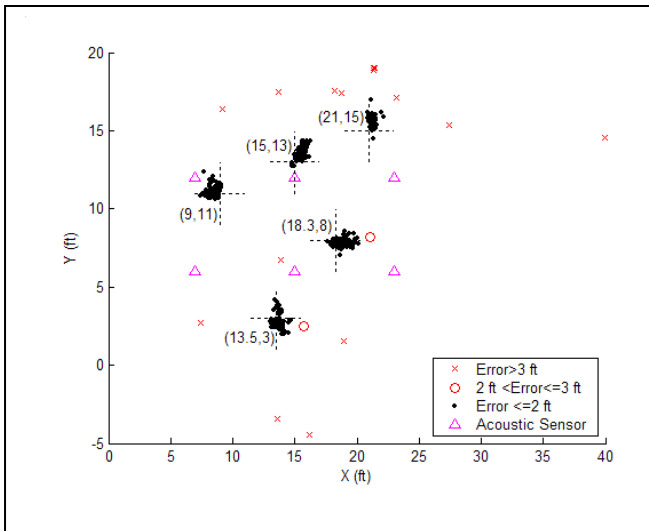

Figure 6. Distribution of reported points (X-Y)

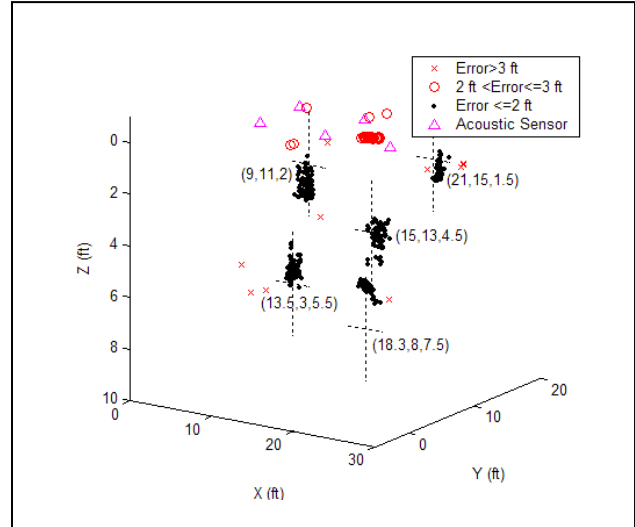

Figure 7. Distribution of reported points (X-Y-Z)

| | | Figure 6 | | Figure 7 | |
|---|--------------|--------------------|----------------------|-----------|------------|
| | x, y, z | \bar{x}, \bar{y} | σ_x, σ_y | \bar{z} | σ_z |
| 1 | 9, 11, 2 | 8.63, 11.1 | 0.64, 0.55 | 2.82 | 0.39 |
| 2 | 13.5, 3, 5.5 | 13.79, 2.66 | 1.27, 1.06 | 5.04 | 0.73 |
| 3 | 15, 13, 4.5 | 15.72, 13.52 | 1.58, 0.43 | 4.8 | 0.811 |
| 4 | 18.3, 8, 7.5 | 18.95, 7.88 | 0.62, 0.86 | 5.87 | 1.6 |
| 5 | 21, 15, 1.5 | 21.77, 15.78 | 2.35, 0.94 | 2.33 | 2.86 |

Table 1. Measurements corresponding to Figures 6 and 7

point; it also gives a visual representation of the error margin of our algorithm (the dotted lines extend up to 2 ft on either side of the test points). Figure 7 shows the results when all the 3 coordinates of the measured location are considered. Table 1 shows the mean and standard deviation of the measured positions (illustrated in Figure 6 and Figure 7) for each of the 5 points. The values of \bar{x} , \bar{y} , σ_x and σ_y for Figure 7 are the same as in Figure 6.

The results show that, for any 2D plane in space (i.e. when only X and Y coordinates of the final position are considered), our location system works with an accuracy of about 2 feet in more than 97% cases, with an iPAQ and the described sensor distribution. The corresponding values for the 3D case are about 3 ft in 95% of the cases.

V. CONCLUSIONS AND FUTURE WORK

In this paper we have presented a cheap indoor positioning system which can be used in places like retail stores, shopping malls, museums, amusement parks, libraries etc. We have also introduced a novel technique of triangulation that is applicable for systems using sensor devices with unpredictable hardware delays. Our location system uses acoustic signal and can measure the position of a user equipped only with a PDA or a similar roaming device. Our experimental results show that the measured position has an accuracy of 2 feet in more than 97% cases. We have also provided an estimate of the number of sensors per unit area in such a system, from which a cost estimate can be easily obtained.

The major concern in this system is the annoyance caused by audio transmission. As such our future work will be towards making the sound more pleasing and less intrusive by blending the acoustic signal with the physical environment. Lopes and Aguiar [7] have already done some work on these lines and we might use some of their ideas.

Secondly, for the time being, we are running the sensor program in desktops as a proof of concept. However in the next phase of the implementation we are going to test the system with a customized sensor hardware module. The sensor module would be battery powered and would typically consist of a very basic sound card (A/D Converter), a wireless (802.11b) network card, a small RAM and a microcontroller. It will be optimized for cost, power and performance.

The other major work in the future would consist of making the system more robust in noisy environments. This can be done by designing the signal differently. Instead of having a single frequency signal we can use a signal with a specific pattern which cannot be present in any kind of noise. However reliable detection of such signals would require improved signal processing techniques.

Finally the accuracy of the positioning system can be increased further by assuming a Gaussian distribution on the reported distances. As part of our future work we will come up with a probabilistic model, based on Bayesian statistical framework, and use it for positioning to obtain high accuracy in real environments where errors due to reflection from obstacles and background noise are common.

ACKNOWLEDGEMENT

This work has been supported by the University of California MICRO grant no. MS-33822, in partnership with Microsoft Corporation. The authors would like to thank the anonymous reviewers for their useful comments and suggestions.

REFERENCES

- [1] J. Hightower and G. Borriello, "A Survey and Taxonomy of Location Sensing Systems for Ubiquitous Computing," *IEEE Computer*, Vol.34, No.8, pp. 57-66, August 2001.
- [2] R. Want, A. Hopper, V. Falcao, J. Gibbons., "The Active Badge Location System," *ACM Transactions on Information Systems*, Vol. 40, No. 1, pp. 91-102, January 1992
- [3] A. Harter, A. Hopper, P. Steggle, A. Ward, and P. Webster, "The anatomy of a context-aware application," In Proceedings of the 5th Annual ACM/IEEE International Conference on Mobile Computing and Networking, (MOBICOM '99), pp. 59-68, 1999.
- [4] N.B. Priyantha, A. Chakraborty, H. Balakrishnan, "The Cricket Location-Support system," In Proceedings of the 6th ACM MOBICOM, August 2000.
- [5] Y. Fukujū et al, "DOLPHIN: An Autonomous Indoor Positioning System in Ubiquitous Computing Environment," *IEEE Workshop on Software Technologies for Future Embedded Systems*, pp.53-56, May 2003
- [6] P. Bahl and V. N. Padmanabhan, "RADAR: An In building RF-based User Location and Tracking System," In Proceedings of the Nineteenth Annual Joint Conference of the IEEE Computer and Communications Societies, INFOCOM 2000, Vol. 2, pp. 775-784, March 2000
- [7] C.V. Lopes and P. Aguiar, "Aerial Acoustic Communications," In Proceedings of the IEEE Workshop on Applications of Signal Processing in Audio and Acoustics (WASPAA'2001), pp. 219-222, Oct. 2001.
- [8] A. Madhavapeddy, D. Scott, R. Sharp, "Context-Aware Computing with Sound," In Proceedings of The 5th International Conference on Ubiquitous Computing, October 2003
- [9] J. C. Chen et al., "Coherent Acoustic Array Processing and Localization on Wireless Sensor Networks," *Proc. of the IEEE*, vol. 91, no. 8, pp. 1154-1162, August 2003.
- [10] J.G. Proakis, D.G. Manolakis, *Introduction to Digital Signal Processing*, Macmillan Publishing Company, 1988
- [11] D.E. Manolakis, "Efficient Solution and Performance Analysis of 3-D Position Estimation by Trilateration," *IEEE Trans. on Aerospace and Electronic Systems*, Vol. 32, No. 4, October 1996, pp. 1239-1248
- [12] F. Diggelen and C. Abraham, "Indoor GPS Technology", CTIA Wireless-Agenda, Dallas, TX, May 2001.